

NEW

Electric Submersible Sewage Pumps
*Electropompes Submersible pour
Eaux Usées*
**Elettropompe Sommergibili
per Acque Reflue**



DRYWET SYSTEM

Caprari International Patent

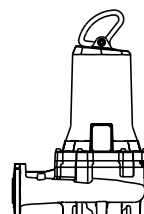

caprari
pumping power



caprari

pumping power

**NEW
SUBMERSIBLE SEWAGE PUMPS**

The new K+ Energy electric pumps are designed to ensure a premium efficiency level thanks to motors in IE3 efficiency class.

The Energy range features the new patented "DryWet" cooling system, which allows its use both in the tank and in the dry chamber. Reliability, robustness and duration features that have always distinguished the K+ hydraulic systems remain unchanged.

**NOUVELLES
POMPES À EAU USÉES IMMERGÉES**

Les nouvelles électropompes K+ Energy sont conçues pour assurer des rendements supérieurs, grâce aux moteurs en classe d'efficacité IE3.

La gamme Energy est équipée du nouveau système de refroidissement breveté "DryWet" pour utilisation aussi bien en bêche qu'en cale sèche. Les caractéristiques de fiabilité, de résistance et de durée qui distinguent les produits hydrauliques K+ non-stop restent inchangées.

**NEW
ELETTROPOMPE SOMMERGIBILI PER
ACQUE REFLUE**

Le nuove elettropompe K+ Energy sono progettate per garantire un'efficienza premium grazie ai motori in classe di efficienza IE3.

La gamma Energy è dotata del nuovo sistema di raffreddamento brevettato "DryWet" system che ne consente l'impiego sia in vasca che in camera asciutta. Rimangono immutate le caratteristiche di affidabilità, robustezza e durata che contraddistinguono le idrauliche K+ non stop.

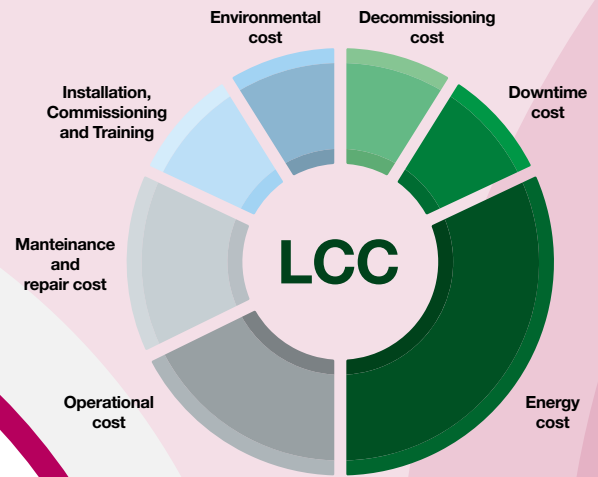

TOTAL FLEXIBILITY

DRY PIT

WET PIT

C NSSHOU-J double shielded cable, normally used for ATEX versions, used also for standard electric pumps.
Le câble NSSHOU-J à double blindage, normalement dédié aux versions ATEX, est assemblé aussi sur les électropompes standard.
Cavo NSSHOU-J a doppia schermatura, dedicato normalmente alle versioni ATEX, utilizzato anche sulle elettropompe standard.

C The plug prevents humidity from entering the motor and allows to significantly reduce maintenance times.
La broche empêche à l'humidité d'entrer dans le moteur et permet de réduire considérablement les temps d'entretien.
Lo spinotto previene l'ingresso di umidità nel motore e consente di ridurre significativamente i tempi di manutenzione.

C Patented DRYWET cooling system, standard on all electric pumps.
Système de refroidissement breveté DRYWET standard sur toutes les électropompes.
Sistema di raffreddamento brevettato DRYWET, standard su tutte le elettropompe.

Caprari International Patent

C Anti-clogging system.
Système anti-colmatage.
Sistema antintasamento.



C Class H electrical insulation, ensuring maximum thermal overload resistance.
Isolation électrique en classe H assurant la plus haute résistance aux surcharges thermiques.
Isolamento elettrico in classe H a garanzia di massima resistenza ai sovraccarichi termici.

C Motors in IE3 efficiency class as defined in Regulation 640/2009.
Moteurs en classe de rendement IE3 conformément au Règlement 640/2009.
Motori in classe di efficienza IE3 like secondo quanto definito nel Regolamento 640/2009.

C Probe in the oil chamber also for ATEX version.
Sonde en chambre d'huile aussi pour la version ATEX.
Sondino in camera olio anche per la versione ATEX.

C Two separated mechanical seals to ensure total motor protection. New simplified disassembly system.
Deux garnitures mécaniques séparées assurant la protection totale de la partie électrique. Nouveau système de désassemblage simplifié.
Due tenute meccaniche separate a garanzia di totale protezione della parte elettrica. Nuovo sistema di smontaggio semplificato.

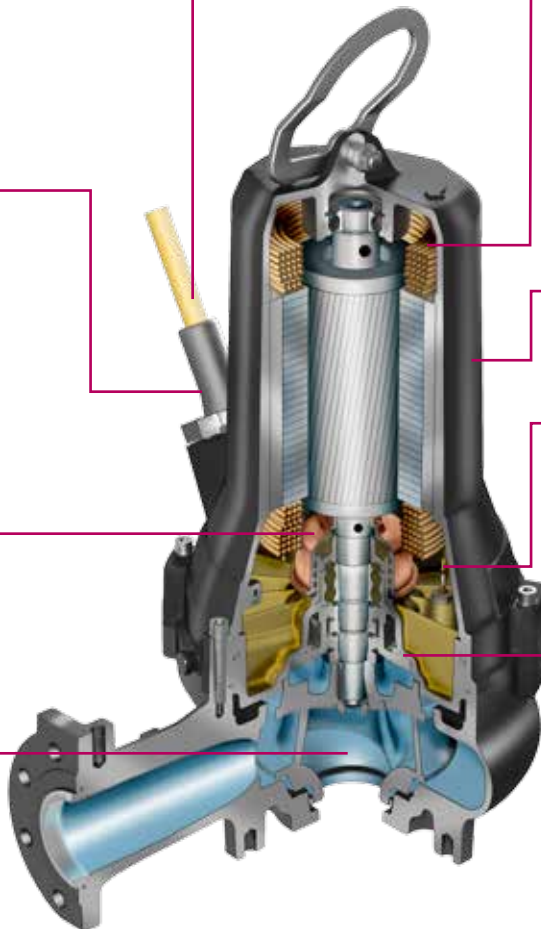

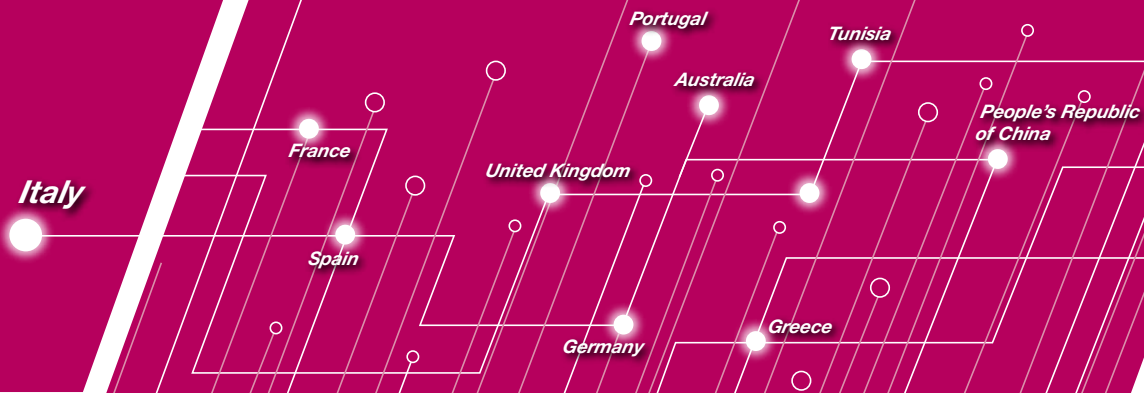

CAPRARI SPA Modena (Italy) • **CAPRARI FRANCE SARL** Maurepas - Paris (France) • **BOMBAS CAPRARI SA** Alcalà de Henares Madrid (Spain) • **CAPRARI PUMPS (U.K.) LTD** Peterborough (United Kingdom)
CAPRARI PUMPEN GMBH Fürth/Bayern (Germany) • **CAPRARI PORTUGAL LDA** Santarém (Portugal)
CAPRARI PUMPS AUSTRALIA PTY LTD Beverley SA (Australia) • **CAPRARI HELLAS SA** Thessaloniki (Greece)
CAPRARI TUNISIE SA Ben Arous (Tunisia) • **CAPRARI PUMPS (SHANGHAI) CO LTD** Shanghai (People's Republic of China)

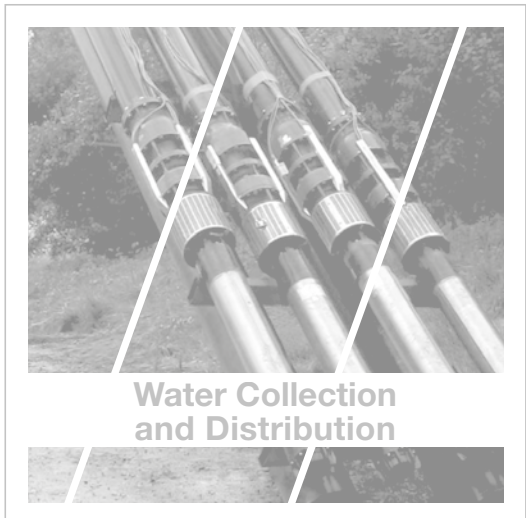

Water Collection and Distribution



Boosting and Distribution of surface water

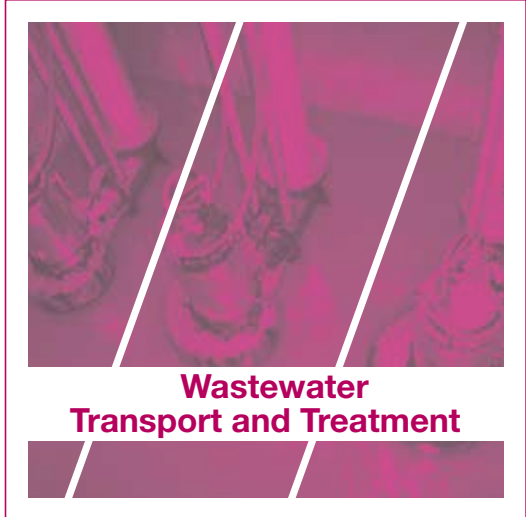

Wastewater Transport and Treatment



Pump Control Technology

caprari
pumping power



www.caprari.com